



BEFORE USING

**REGISTER YOUR
ANALYZER**



***Scan Now for Easy Online Registration
or Visit www.ueitest.com***



C165 OVERVIEW

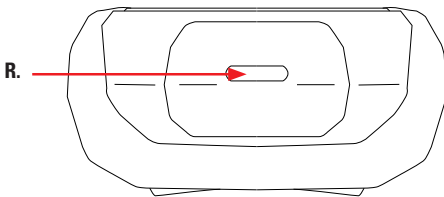
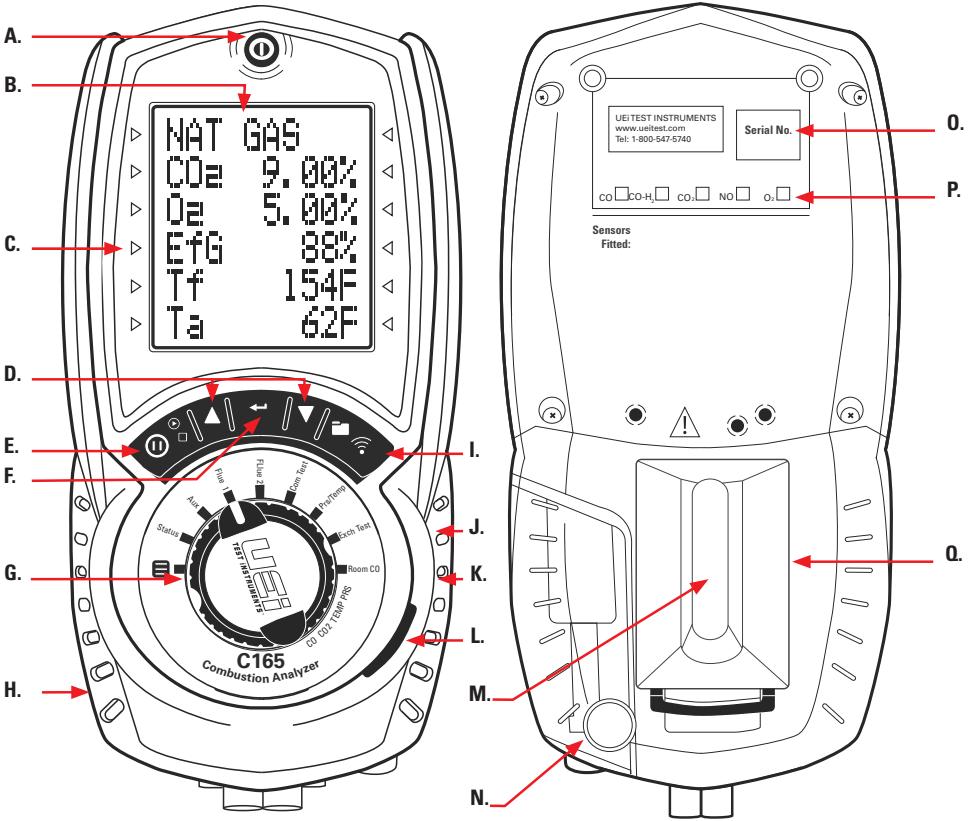

[Top View]

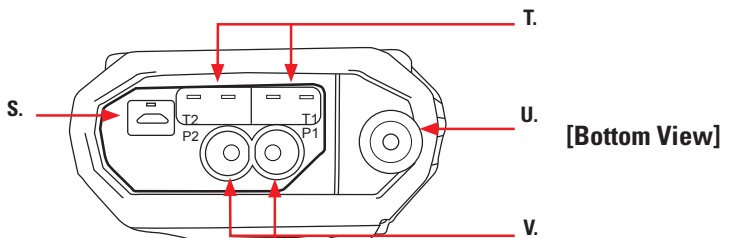

[Bottom View]

A. On/ Off (Power) Button

B. 6 Line Backlit Display

- Press any button to turn Back light on (backlight duration can be set in Menu/Screen/Backlight)

C. Display Line Lights

D. UP/DOWN Button

- Short press to navigate “UP” or “DOWN”

E. Pump Toggle button: Long press to pump on/off, short press holds the readings and the screen flashes

F. ENTER Button

- Short press select current option displayed

G. Rotary Selector Dial

H. Protective Rubber Boot With Magnets

I. Printing and log button: Long press to saving logs and Short press to print on/off

J. Water Trap (under Protective Boot)

K. Particle Filter (inside water trap)

L. LED Water Trap Indication: LED is active while the pump is on to bring user awareness to any condensate building up in the water trap

M. Grip Indentation: Indentation for fingers to grip analyzer

N. Water Trap Drain Plug: (Red plug; take caution NOT to damage plug when removing protective boot)

O. Serial Number QR Code

P. Sensors Fitted: (label under Protective Boot) Indication of sensors installed when shipped (CO, CO-H₂, CO₂, NO, O₂)

Q. Battery Compartment (under Protective Boot)

R. Infrared Printer Port

S. Battery Charge USB Adapter Connection

T. Temperature Connections

- Flue Probe Temperature: T1
- Inlet Temperature: T2

U. Flue Gas Inlet Connection

V. Pressure Connections

- Pressure: P1
- Differential Pressure: P2

MENU SCREEN - C165 START UP

Press **Ⓞ** "Power" Button for 2 seconds. The analyzer will perform a 10 second purge. This should be done in fresh air.

Rotate Selector Dial to **MENU** to set up or customize your settings.

Selected parameter are highlighted with Display Line Lights on either side.

Use **▲** and **▼** **ARROW BUTTONS** to scroll menu options.

Press **←** **Button** to edit a parameter.

Press **▲** and **▼** **ARROW BUTTONS** to change contents of field.

Press **←** **Button** to enter content and move to next field.

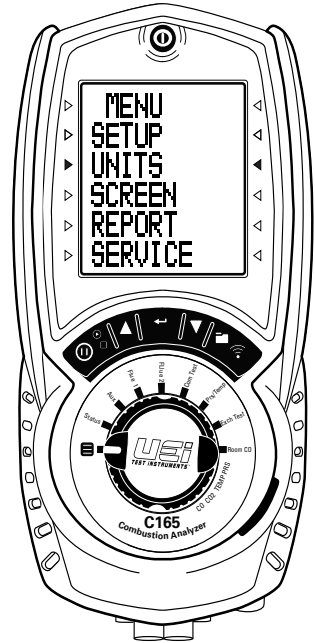

STATUS SCREEN

Rotate Selector Dial to **STATUS** to view parameters

Selected Fuel

FUEL TYPE

TIME

DATE

AMBIENT TEMPERATURE

CALIBRATION DAY COUNTDOWN

BATTERY LEVEL

Change Fuel Type

With the first line selected press **▲** and **▼** **ARROW BUTTONS** to change currently selected Fuel. (Nat Gas, Town Gas, Coke Gas, Butane, Propane, LPG, Light Oil, Bio Oil, Wood Pellets, Bio Gas, User Gas 1, 2, 3, 4, 5)

Press **←** **Button** to select.

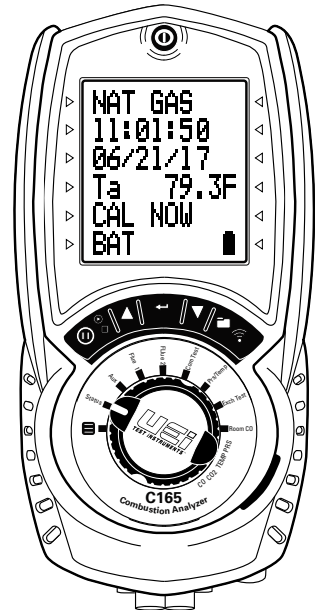

BEFORE TESTING

CHECKLIST

- Clean particle filter
- Water trap and probe line are free of condensate
- All hose and thermocouple connections are properly secured
- Water trap is fitted correctly
- Power on and zero
- Flue gas probe is sampling ambient **FRESH** air

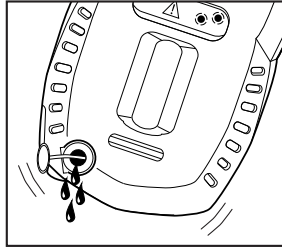

Remove the rubber boot and red drain plug. Allow the water to drain out. Re-insert the rubber plug and replace boot cover.

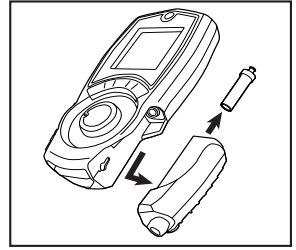

Remove protective rubber boot. Remove water trap from analyzer. Remove particle filter from water trap and replace with new one. Reattach trap and boot.

AUXILIARY SCREEN

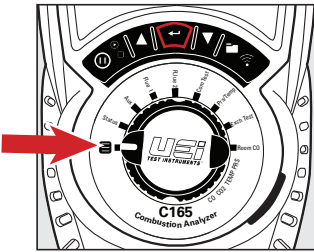



The **AUX** screen allows you to assign any of the following parameters on any display line. CO₂, CO, NO (if fitted), NO_x (if fitted), O₂, TF, Ti, Ta, Delta T, Loss, Efg, Xair, Ra (CO/CO₂ Ratio), Pl, Fuel Type, PRS or Blank.



To customize the settings displayed on screen.

Rotate dial to .

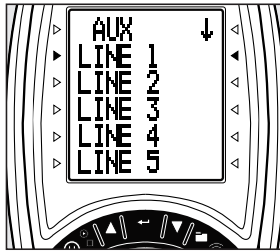

Scroll  or  to **SCREEN**. Press .



Scroll  or  to **AUX**. Press .



Scroll  or  to select the line to change. Press .

Highlighted line shows current selection.

Scroll  or  to change parameters. Press .

Scroll  or  to select another line to customize and repeat.

When finished, scroll  or  to **BACK**.

Press .

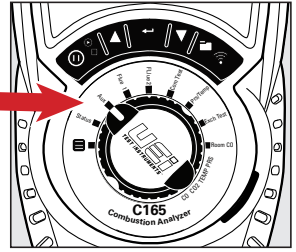

When performing a combustion Test.

Rotate function rotary dial to **AUX** to Test while viewing custom parameters that you selected.

BASIC CO/COMBUSTION ANALYSIS

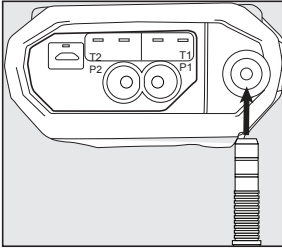

Insert Flue probe into stack.
Adjust cone so end of the probe is approximately at the center of the stack.

NOTE: You will have to drill a hole at least 3/8". Use appropriate sealing method after testing.

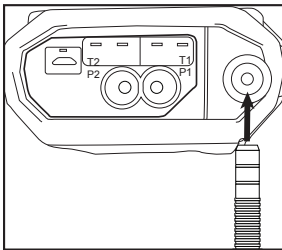

Once complete, remove probe from stack, allow analyzer to purge in fresh air until CO sensor readings return to ZERO (0) and O₂ readings reading return to 20.9%.

Continue to the next test or power analyzer off by pressing , if finished.

NOTE: Print and store functions may be used at any time during testing.

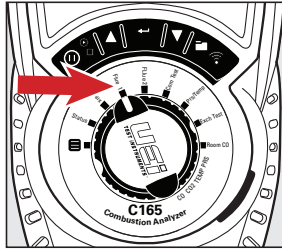

Rotate selector dial to **FLUE 1** to view:

Fuel Type, CO₂, O₂, Efficiency, Flue Temperature and Inlet Temperature.

Fuel type can be changed via  or **STATUS** setting

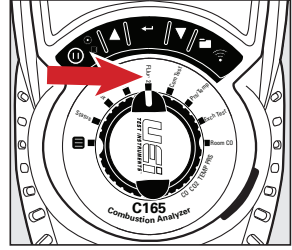

Rotate selector dial to **FLUE 2** to view:

Fuel type, CO, CO_a, Losses, Xair and Pressure.

Fuel type can be changed via  or **STATUS** setting.

Make any adjustments as needed for proper combustion and wait for analyzer to display change in readings. (Repeat as necessary).

COMMISSIONING TEST

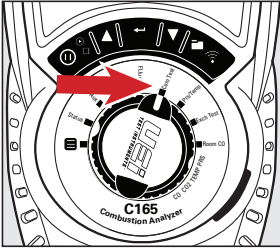

Rotate the rotary dial to
COM TEST

The Commissioning Test is based on UK's TB143 Introduced in April 2013, Technical Bulletin 143 from the Heating and Hotwater Industry Council (HHIC), outlines a safer, clear and comprehensive procedure for commissioning condensing boilers without airgas ratio valves.

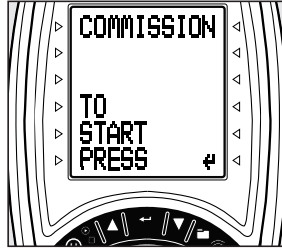

Rotate the dial to "**COM TEST**" position and follow the instructions on the screen

PRESSURE TEST

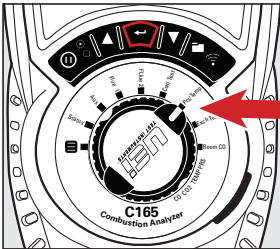

Rotate the selector dial to
PRS/TEMP.

Press  to Zero Pressure sensor. No connections when zeroing pressure.

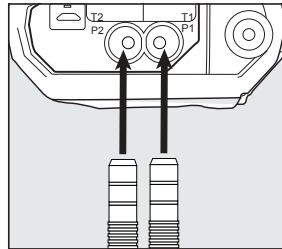

Connect true draft hose to P1. Connect second probe to P2 for differential pressure.

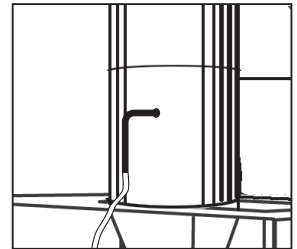

Place combustion probe or true draft probe tip in the flue to measure draft.

Connect static pressure hose to measure differential pressure.

TEMPERATURE TEST

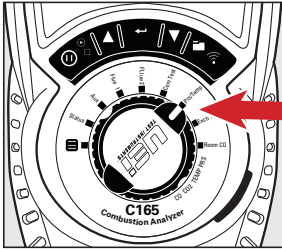

Rotate the selector dial to
PRs/TEMP

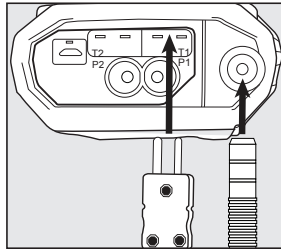

Connect probe to T1.
Compatible with any K-Type
thermocouple probe or clamp.

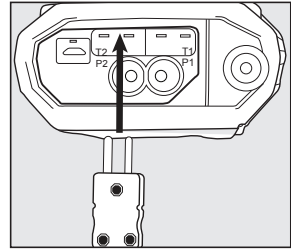

Connect second probe to T2.
Compatible with any K-Type
thermocouple probe or clamp.

HEAT EXCHANGER TEST

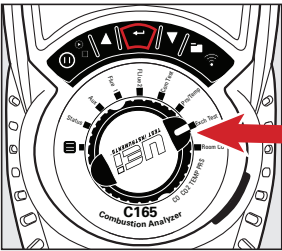

Rotate dial to **EXCH TEST**.
Press **←** to start.

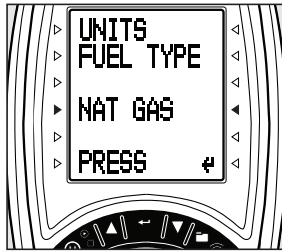

Scroll **▲** or **▼** to select
FUELTYPE.
Press **←**

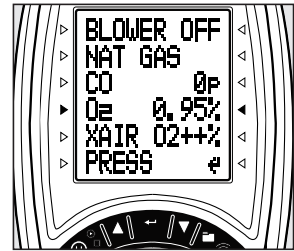

Call for heat on the system.
Observe and wait for O₂
readings to stabilize.

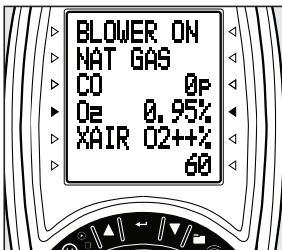

The analyzer will wait 60
seconds and then record the
Post-Blower values for CO,
O₂ and Excess Air.

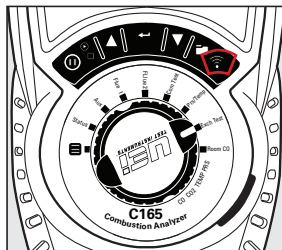

Test results and **LOG**
number will display when done.

Press **📶** to print the results.
This **LOG** will be stored in
REPORTS/EXCHANGE in the
MENU screen.

After the blower turns on,
press the **←** to start the
Post-Blower test

ROOM CO TEST

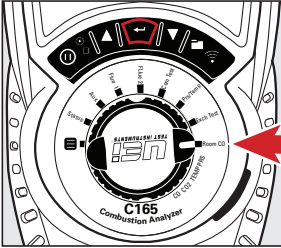

No probes or hose connections required for this test.

Rotate dial to **ROOM CO**.
Press to select **GENERAL** test type.

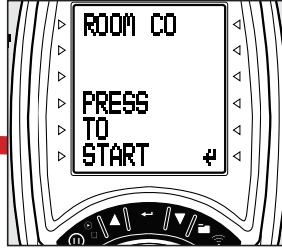

CO readings will be logged every 2 minutes for 30 minutes.

Readings will be stored once the 30 minute test is completed.

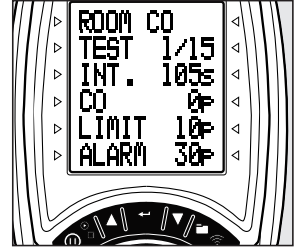

Test results and **LOG** number will display when done.

Press to print the results.

This **LOG** will be stored in **REPORTS/ROOM CO** in the **MENU** screen.

PRINTING AND LOGGING

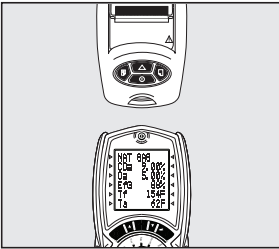

Align Printer in line above analyzer.

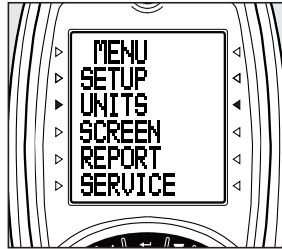

Rotate rotary dial to **Menu**.
Press or Buttons to select **Report**.

Press Button to select **Report**.

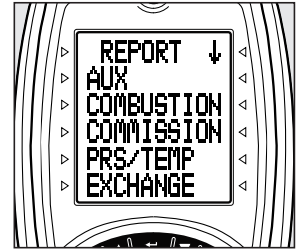

Press or Buttons to view types of **Reports**.

Press Button to select Report type.

Press Button to **View**.

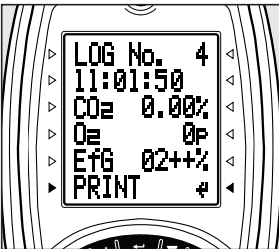

Press or Buttons to select Log number of that type of Report.

Scroll or to **PRINT**.

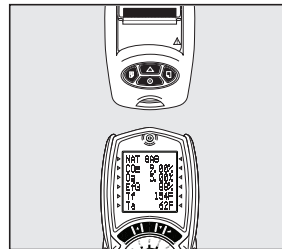

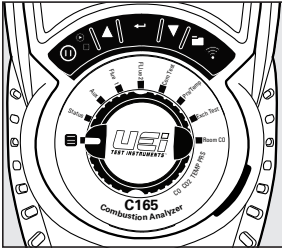

Press Button to print Report Log Number.

SETUP USER FUEL



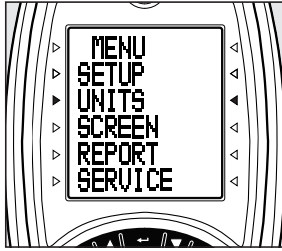

Rotate dial to **Menu**

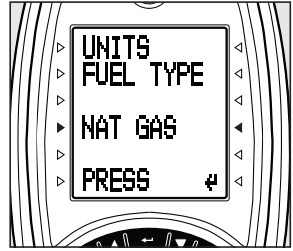

UNITS shows press  to proceed.



Press  or  to **USERFUEL (1-5)**
Press **ENTER**  to proceed.

POST TESTING

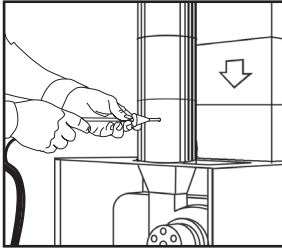

Remove the probe from the flue and allow analyzer to purge with fresh air until readings return to zero. O₂ to 20.9%

CAUTION: probe tip will be HOT.

POWERING OFF

When you power off the C165, there is a 10 second purge.

CAUTION

Make sure you do not exceed the analyzer's operating specifications.

- Do not exceed the flue probes maximum temperature (1112°F)
- Do not exceed the analyzer's internal temperature range 112°F (50°C)
- Do not put the analyzer on a hot surface
- Do not exceed the water trap's level
- Do not let the particle filter become dirty and blocked

BATTERIES



The analyzer is fitted with 3 (AA) size rechargeable batteries. Observe correct polarity when replacing.

Always check operation immediately after battery replacement.

Do not leave batteries in unit for extended periods of non-use.

WARNING

Do not recharge with Alkaline batteries fitted. Alkaline batteries are not rechargeable. Attempting to recharge alkaline batteries may result in product damage and create a fire risk.

Time and Date will need to be reset after changing batteries. Always dispose batteries using approved disposal methods that protect the environment.



**Download the full
Owners Manual at
UEiTEST.COM or
SCAN THIS CODE**

WARRANTY

The C165 combustion analyzer is warranted for one year. Warranty is a manufacturing defect identified within the product's warranty period. Warranty does not cover batteries, fuses, test leads, probes, consumables physical damage and misuse. For full warranty details please refer to the Owner's Manual on the C165 product page (see the link above). If a UEi product fails under warranty, we will replace it but we need the unit back so we can identify and fix the problem. For an RMA call Team UEi @ 1-800-547-5740.

UEi Test Instruments • 1-800-547-5740 • info@ueitest.com

This warranty gives you specific legal rights. You may also have other rights which vary from state to state.

DYNAMIC WARRANTY

We make it easy to keep your analyzer protected and fit-for-purpose. When you send in your analyzer for annual service, we'll be upfront and transparent about the cost, we'll provide industry-leading service and we always target a 2-business day turnaround. Most importantly, your analyzer is covered for another 12 months and you can do this for up to 6 years of coverage.

READ BEFORE USE

ANNUAL RECERTIFICATION

UEi annual recertification process is straight forward and up front; no surprises!

Pay a flat rate for standard Recertification service.

- *Calibration or Sensor Replacement*
- *30-Point Inspection*
- *Firmware and Software Updates*
- *Certificate of Calibration*
- *Return Freight Paid**
- *12-Month warranty*

*Target 2-Business day turnaround on all standard recertification services with pre-approved payment.***

Our recertification teams are factory certified and proud to provide industry-leading turnaround support.

Our recertification centers in USA and Canada are ISO/IEC 17025:2017 accredited facilities that only use EPA protocol test gases and can provide NIST certification services.

*Return freight pre-paid within the continental US and Canada.

**Standard recertification services does not include repair work to analyzers. Customer Service will contact users directly regarding repair time lines, options and costs prior to performing any repair services.

WWW.UEITEST.COM

USA 1.800.547.5740
CANADA 1.877.475.0648